

COLOR RTV 144

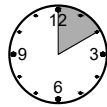
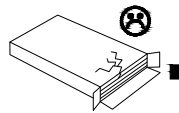
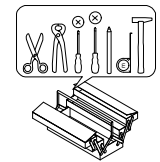
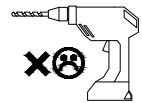
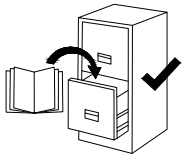
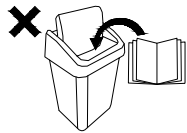
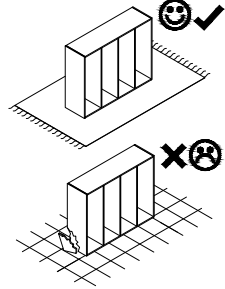
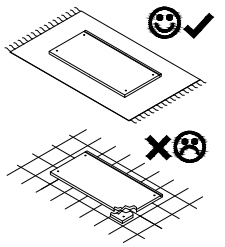
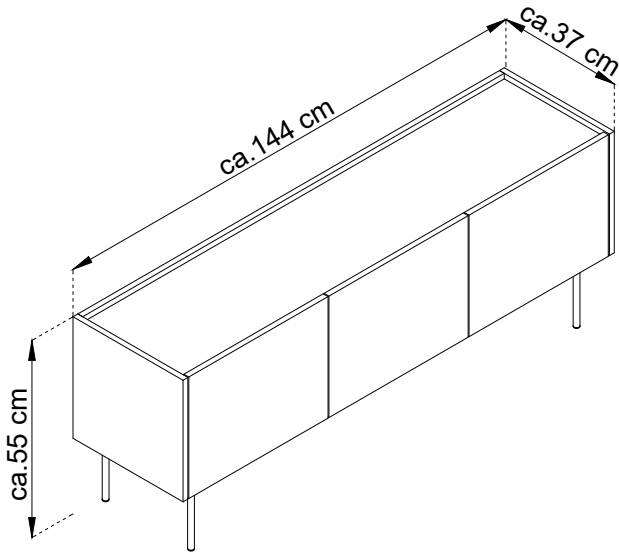

ca. 2H

(D) Montageanleitung

(FR) Notice de montage

(NL) Handleiding voor de montage

(CZ) Montážní návod

(HU) Szerelési útmutató

(TR) Montaj talimatı

(GB) Assembly Instructions

(IT) Istruzioni di montaggio

(PL) Instrukcja montażu

(SK) Návod na montáž

(RO) Instrucțiuni de montaj

(RU) Инструкции по монтажу

PIASKI
SINCE 1989

Fabryka Mebli PIASKI Henryk Kaczorowski sp. z o.o.
PIASKI 1C, 63-645 Łęka Opatowska
gpsr@piaski.com.pl

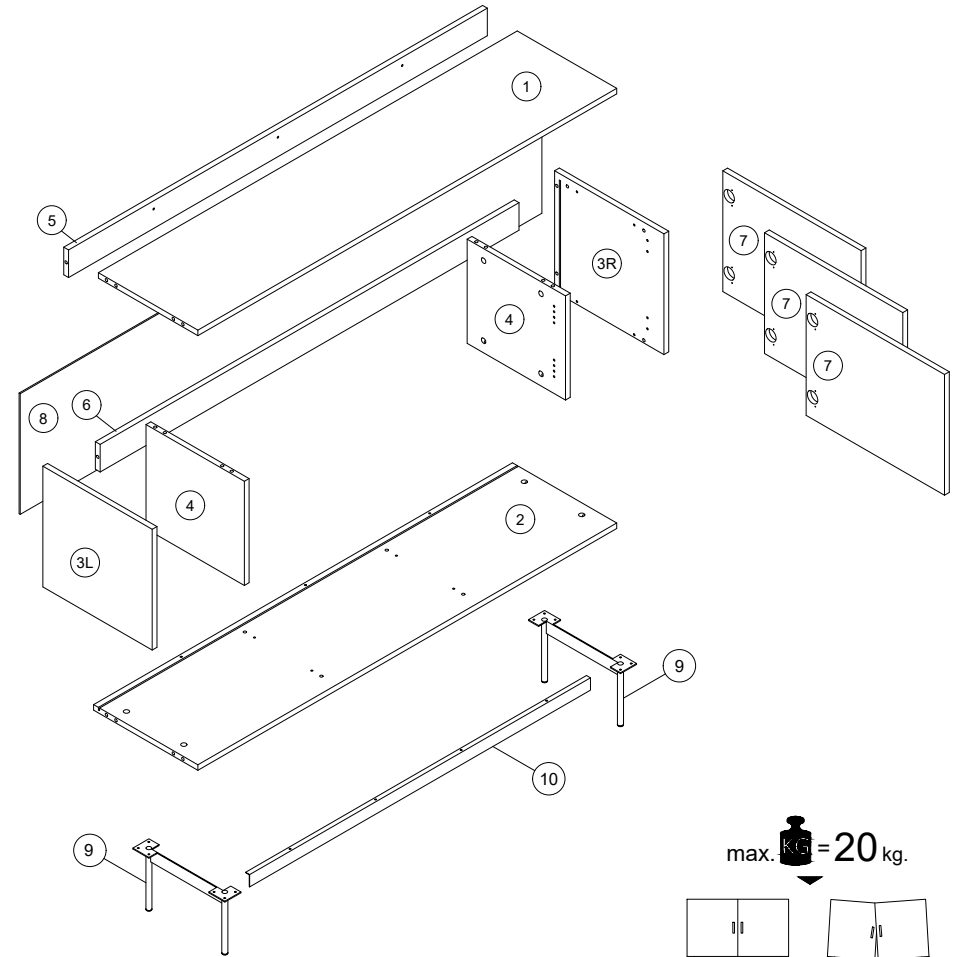

max. = 20 kg.

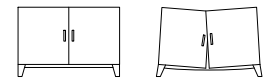

1	1402	332	16	x1	2 / 2
2	1402	349	16	x1	2 / 2
3L	350	366	16	x1	2 / 2
3R	350	366	16	x1	2 / 2
4	329	302	16	x2	2 / 2
5	1402	80	16	x1	2 / 2
6	1402	80	16	x1	2 / 2
7	463	350	16	x3	2 / 2
8	1412	283	2.5	x1	2 / 2
9	344	200	60	x2	1 / 2
10	1275	40	15	x1	2 / 2

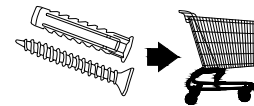

B	C	A	8x32		
				x19	x20
H0	WH	ST	W	4x60	NE 4x16
				x3	
x6	x6	x1			x16
X	X1	ND	3.5x16	N	3x20
x2	x6	x18		x2	
				Z	
				x16	

17.12.2025

⚠ **Uwaga • Upozornění • Achtung • Attention • Caution • Fysylen**
Attenzione • Opreget • Bauwarme • Atención • Upozornenie • Dikkat ⚠

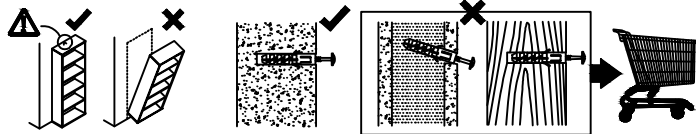
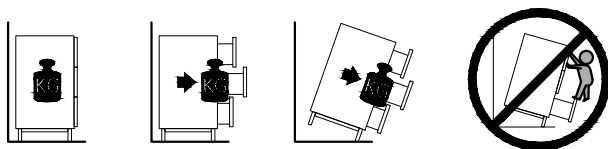

PL	Mocowanie do ściany jest jednocześnie zabezpieczeniem przed przewróceniem - koniecznie zamontować! Do niektórych rodzajów ścian koniecznie zastosować specjalne kołki mocujące.
CZ	Montáž na stěnu slouží jako ochrana proti převrnutí - bezpodmienečně umístěte! U některých typů stěn může být zapotřebí speciální hmoždinka!
DE	Wandbefestigung dient als Kipperschutz - unbedingt anbringen! bei einigen Wandtypen kann ein Spezialdübel erforderlich sein!
GB	The wall fastening serves to prevent tipping - be absolutely sure to mount it! For certain wall types, a special wall plug may be necessary!
FR	La fixation murale sert de protection contre le basculement - à installer impérativement! Pour certains types de murs il faut des chevilles spéciales!
NL	Bevestiging aan de muur dient als kantelbescherming - zeker en vast bevestigen! Bij enkele muurtypes is een speciale plug misschien vereist!
IT	Il fissaggio alla parete serve da protezione anti-ribaltonamento-attaccarla assolutamente! Per alcune strutture di parete può essere necessario un tassello speciale!
HU	A termék a falhoz kell rögzíteni, különben az felborulhat! Egyes fal típusoknál speciális típít kell használni!
RU	Обязательно установите крепление на стене во избежание опрокидывания! Для некоторых типов стен может потребоваться специальный дюбель!
RO	Sistemul de fixare la perete servește ca protecție la răsturnare - de montat obligatoriu! Pentru unele tipuri de pereți este posibil să fie necesar un diblu special!
SK	Upevnenie na stenu slúži ako ochrana proti prevráteniu - bezpodmienečne použiť! Pre niektoré druhy stien môže byť potrebná špeciálna hmoždinka!
TR	Duvardaki sabitleme, devrilmeye karşı bir emniyet tedbiridir ve mutlaka monte edilmelidir! Bazı duvar tiplerinde bunun için özel bir dübel gereklidir!

⚠ **Uwaga • Upozornění • Achtung • Attention • Caution • Fysylen**
Attenzione • Opreget • Bauwarme • Atención • Upozornenie • Dikkat ⚠

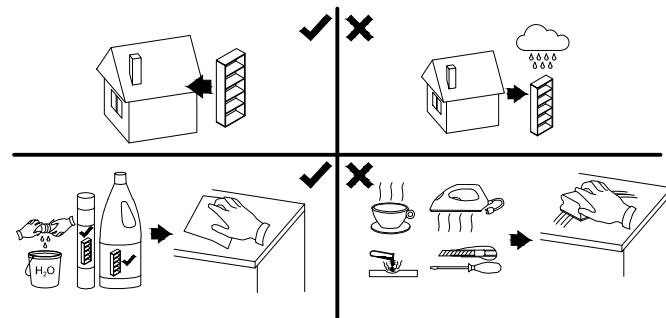

PL	Czyszczenie należy wykonać wyłącznie za pomocą ściereczki lub lekko nawilżonego ręcznika. Nie stosować środków czyszczących do szorowania.
CZ	Čistění je nutné vykonávat výhradně pomocí utěrky nebo lehce navlhčeného ručníku. Nepoužívejte čističky prostředky obsahující abrazivní částice.
DE	Bitte nur mit einem Staubtuch oder leicht feuchten Lappen reinigen. Keine scheuernden Putzmittel verwenden.
GB	Please only clean with a duster or damp cloth. Do not use any abrasive cleaners.
FR	Le nettoyage se fait uniquement à l'aide d'un torchon ou d'une serviette légèrement mouillée.
NL	Reinig alleen met een stofdoek of een lichtjes vochtige doek. Gebruik geen schurende poetsmiddelen.
IT	Pulire esclusivamente con un panno o un asciugamano umido.
HU	A tisztítás kizárólag törölkűruha vagy enyhén nedvesített törölköző segítségével végezhető. Súroló hatású tisztítószereket nem szabad használni.
RU	Очищайте от пыли тряпкой или слегка влажной ветошью. Не допускается применение чистящих средств, не предназначенных для ухода за мебелью.
RO	Curățarea trebuie efectuată numai cu o cârpă sau cu un prosop ușor umezit. Nu utilizați agenți de curățare abrazivi.
SK	Čistení je nutné vykonávať výhradne pomocí utierky alebo ľahko zvlhnutým ručníkom. Nepoužívajte čistiace prostriedky obsahujúci abrazívni častice.
TR	Lüften sadece bir toz bezilye veya hafif nemli yumuşak bir bezle siliniz. Aşındırıcı temizlik malzemeleri kullanmayınız.

1

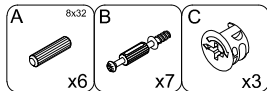
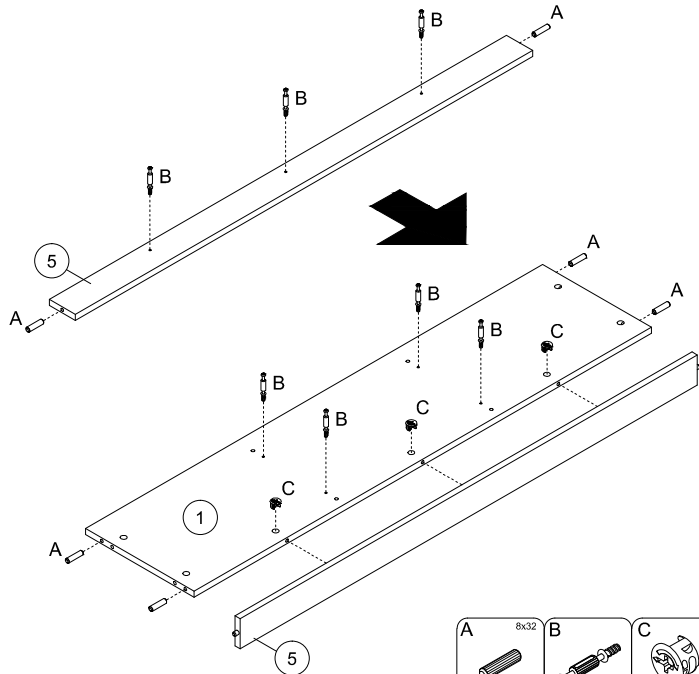
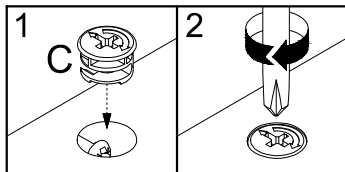
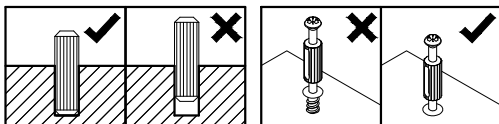
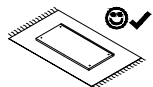

2

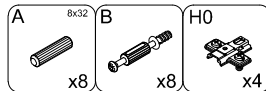
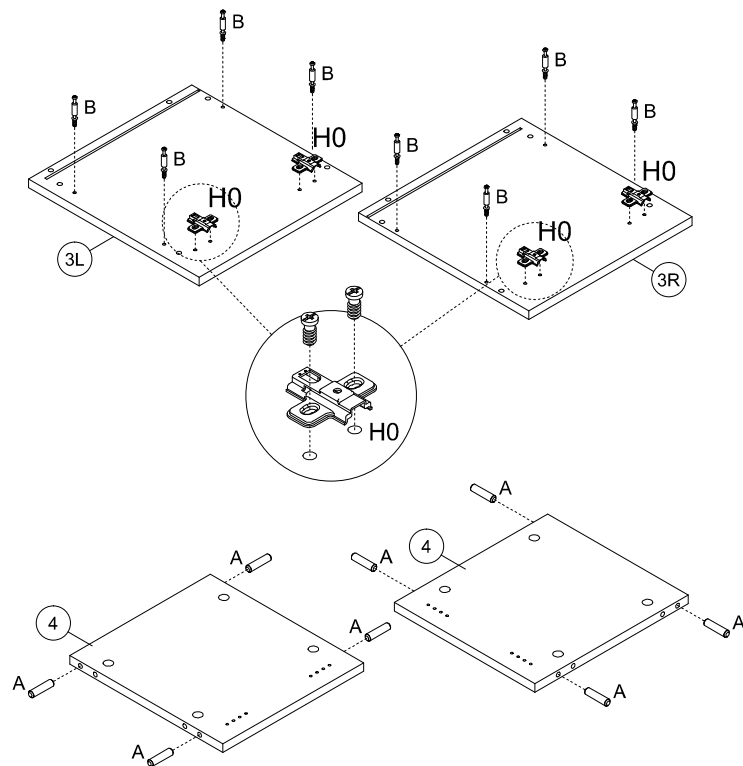
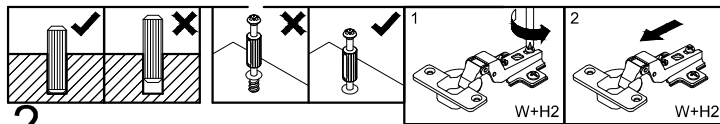

3

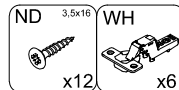
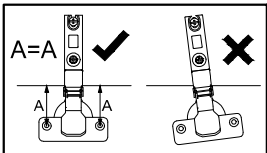
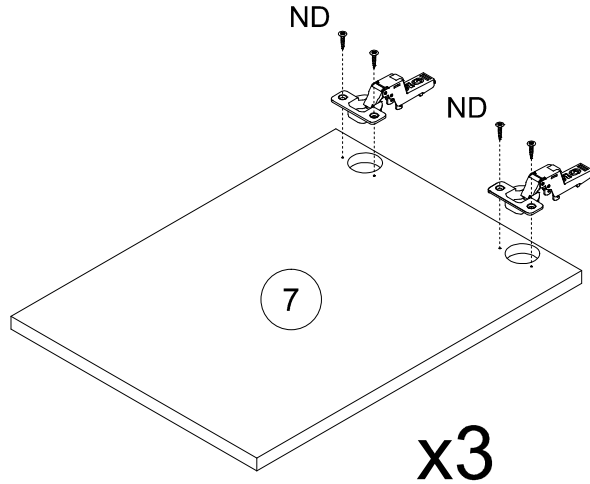
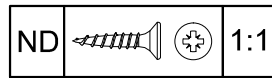

4

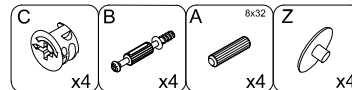
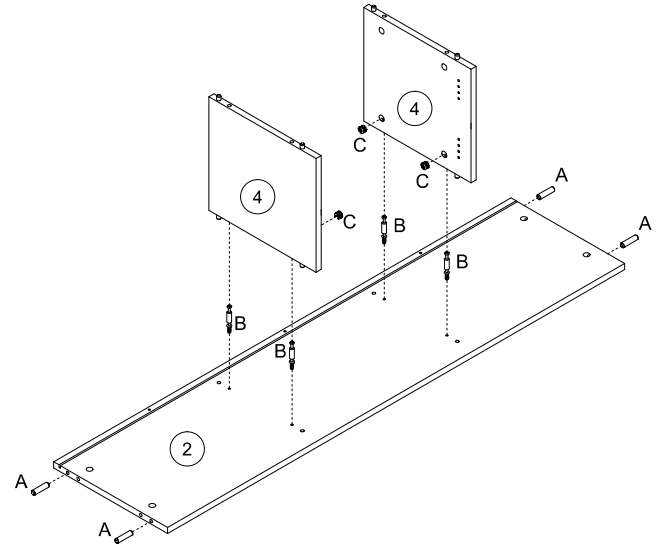
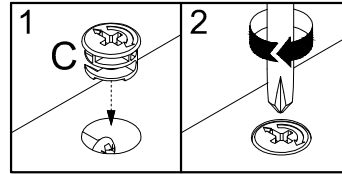

5

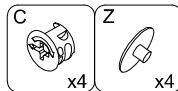
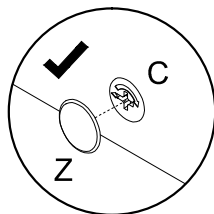
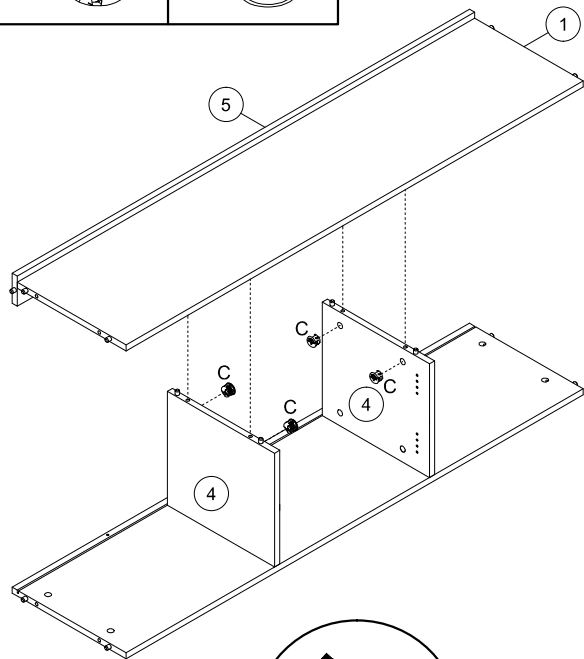
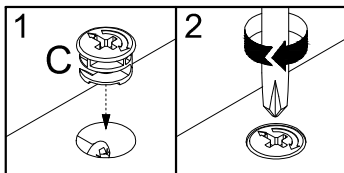

6

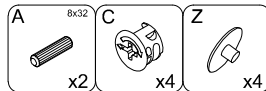
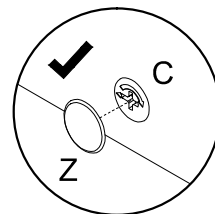
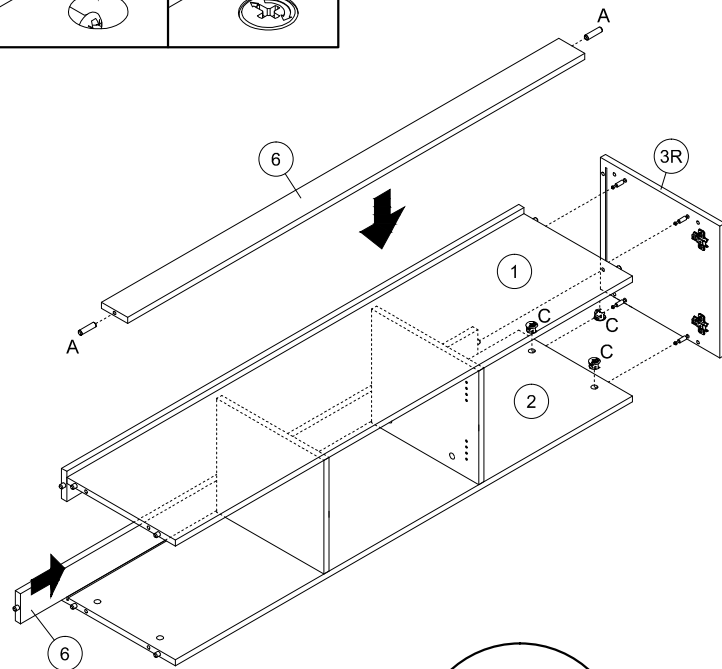
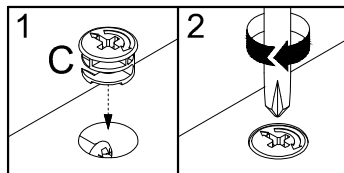

7

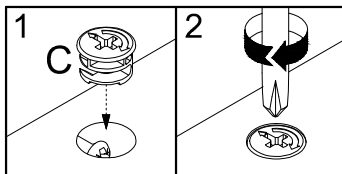
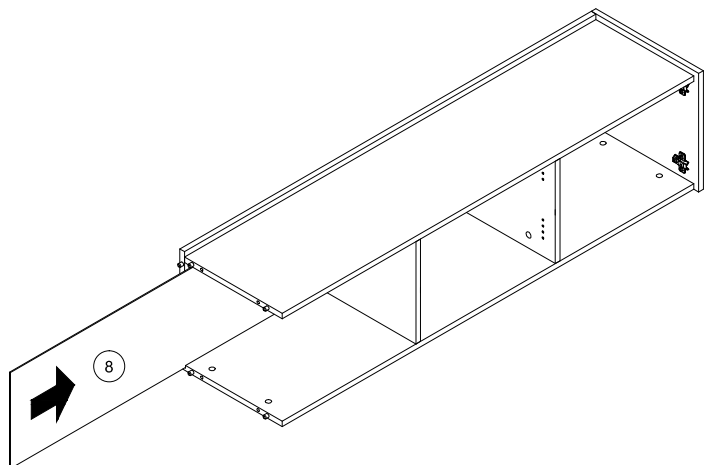

8

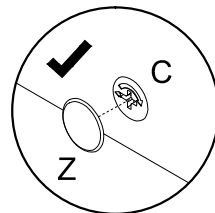
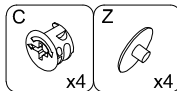
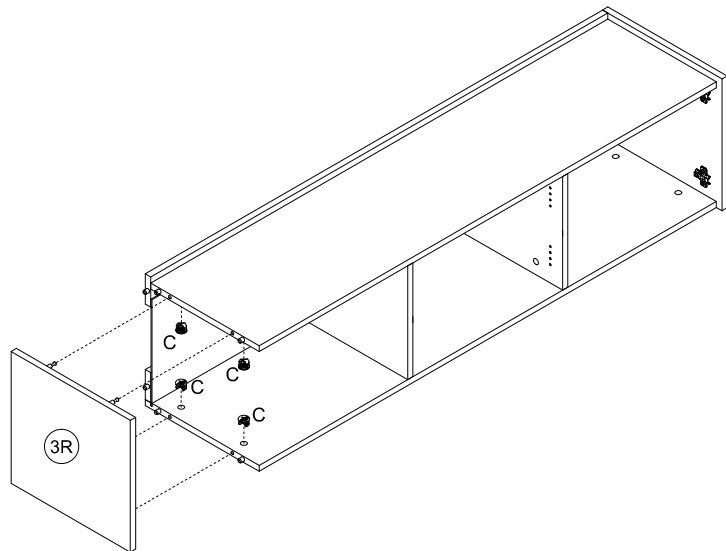

9

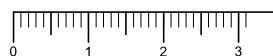
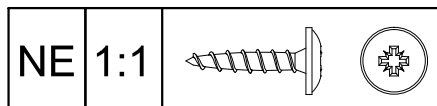
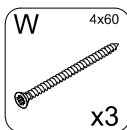
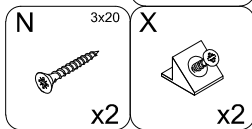
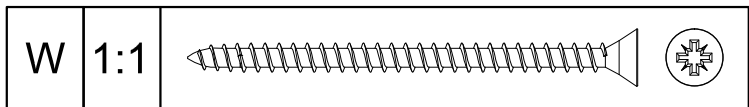
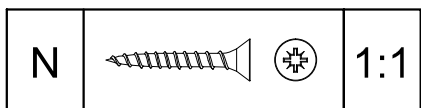
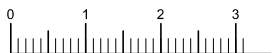
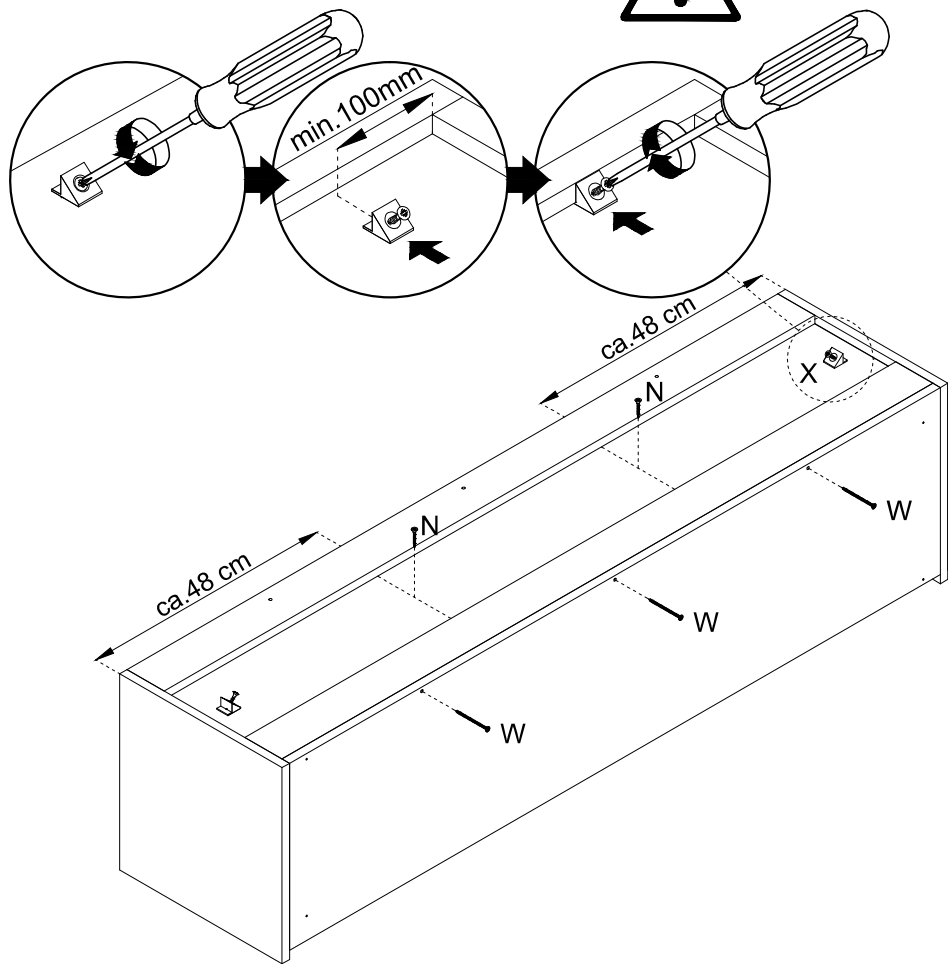
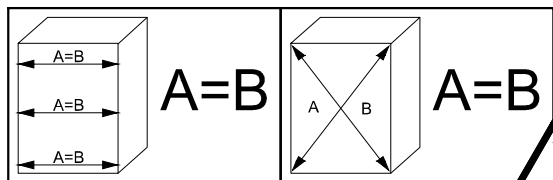

10

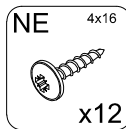
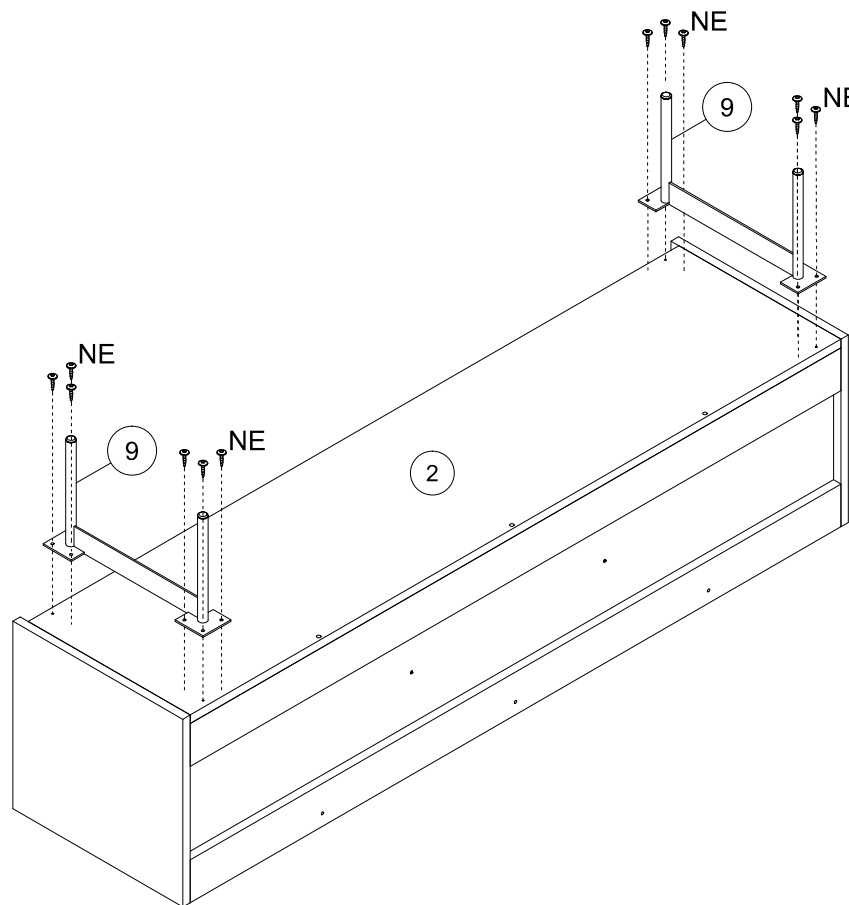

11

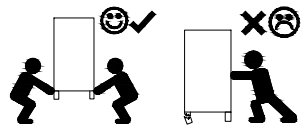
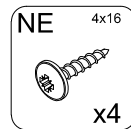
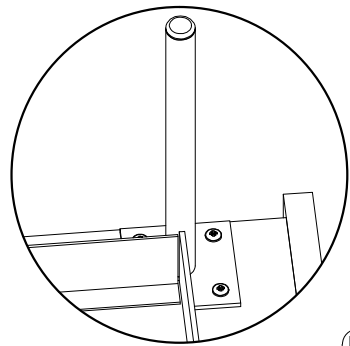
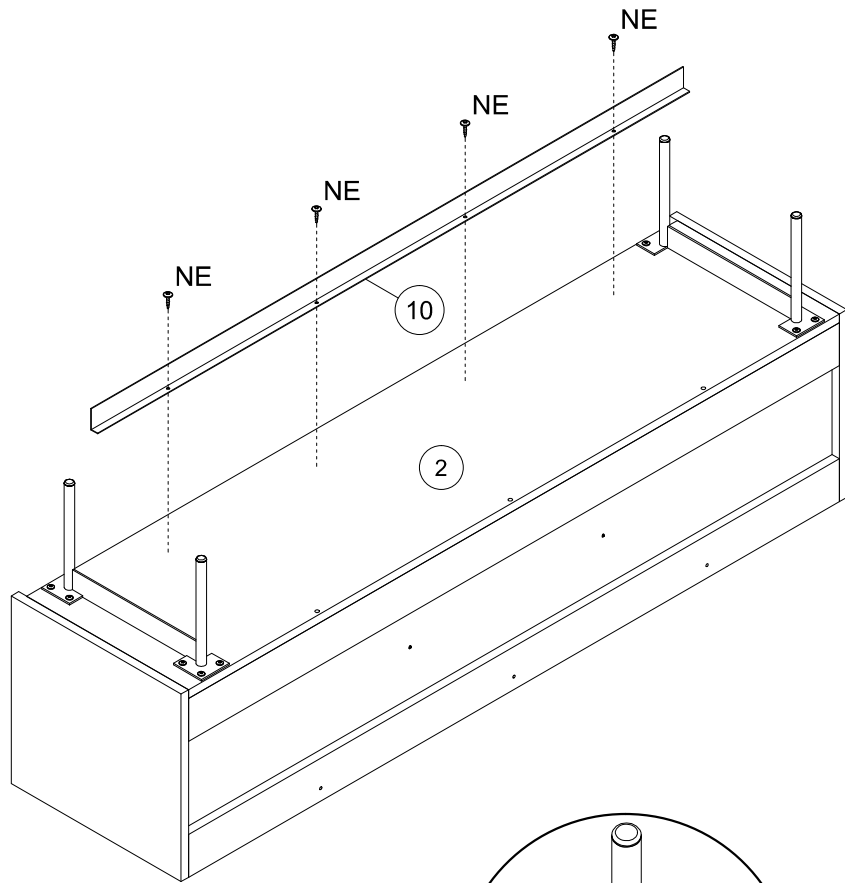

12

